



US 20170271422A1

(19) **United States**

(12) **Patent Application Publication**

KIM et al.

(10) **Pub. No.: US 2017/0271422 A1**

(43) **Pub. Date: Sep. 21, 2017**

(54) **THIN FILM TRANSISTOR AND METHOD OF MANUFACTURING THE SAME, AND ORGANIC LIGHT-EMITTING DISPLAY DEVICE INCLUDING THE SAME**

(52) **U.S. Cl.**
CPC *H01L 27/3262* (2013.01); *H01L 27/3276* (2013.01); *H01L 51/5253* (2013.01); *H01L 27/3258* (2013.01); *H01L 2227/323* (2013.01)

(71) Applicant: **SAMSUNG DISPLAY CO., LTD.**,
Yongin-Si (KR)

(57) **ABSTRACT**

(72) Inventors: **DEOKHOI KIM**, Yongin-Si (KR);
Seunggyu Tae, Yongin-Si (KR)

(21) Appl. No.: **15/455,563**

(22) Filed: **Mar. 10, 2017**

(30) **Foreign Application Priority Data**

Mar. 18, 2016 (KR) 10-2016-0032914

Publication Classification

(51) **Int. Cl.**
H01L 27/32 (2006.01)
H01L 51/52 (2006.01)

An organic light emitting display device is provided as follows. A first thin film transistor having a first semiconductor pattern is disposed on a substrate. A second thin film transistor having a second semiconductor pattern is disposed on the substrate. An insulating layer covers the first thin film transistor and the second thin film transistor. At least one first dummy hole passing through the insulating layer overlaps the first semiconductor pattern of the first thin film transistor. At least one second dummy hole passing through the insulating layer overlaps the second semiconductor pattern of the second thin film transistor. Numbers or sizes of the at least one first dummy hole and the at least one second dummy hole are different from each other.

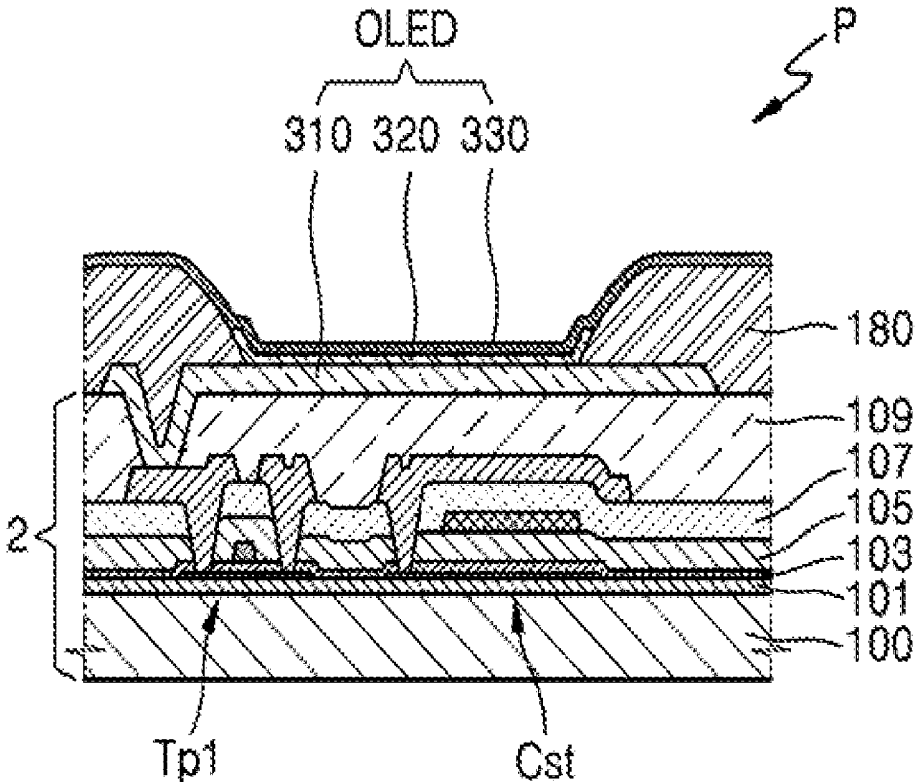

FIG. 1

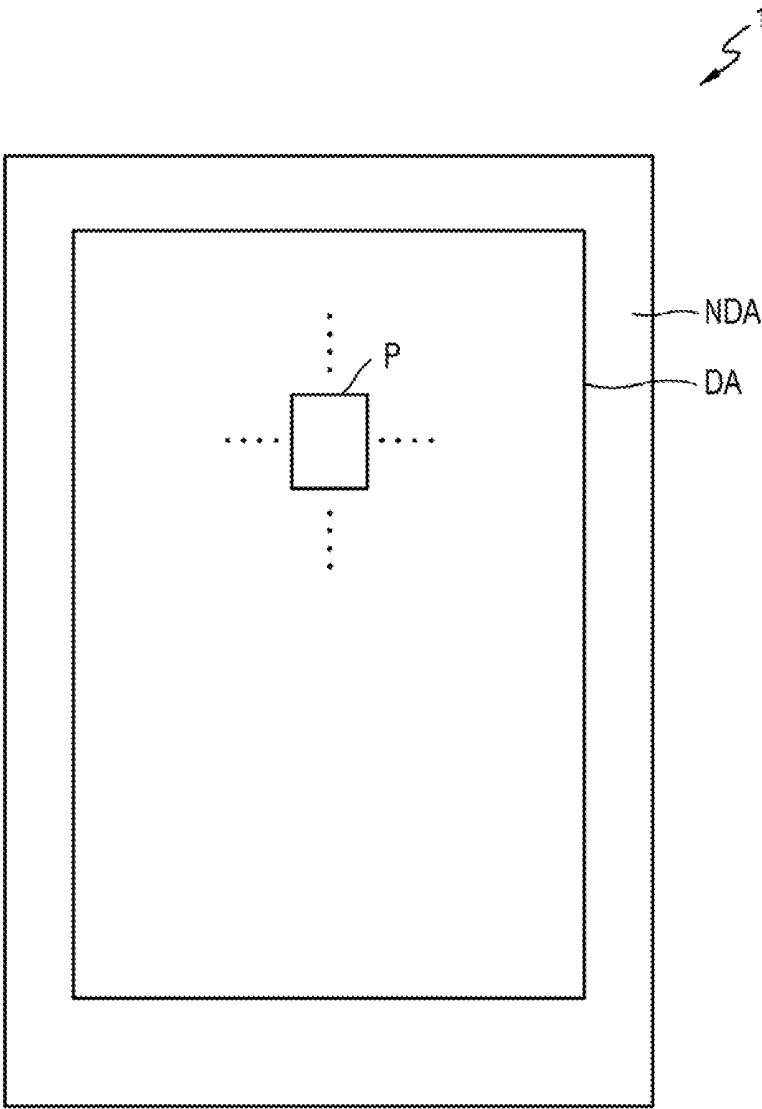

FIG. 2

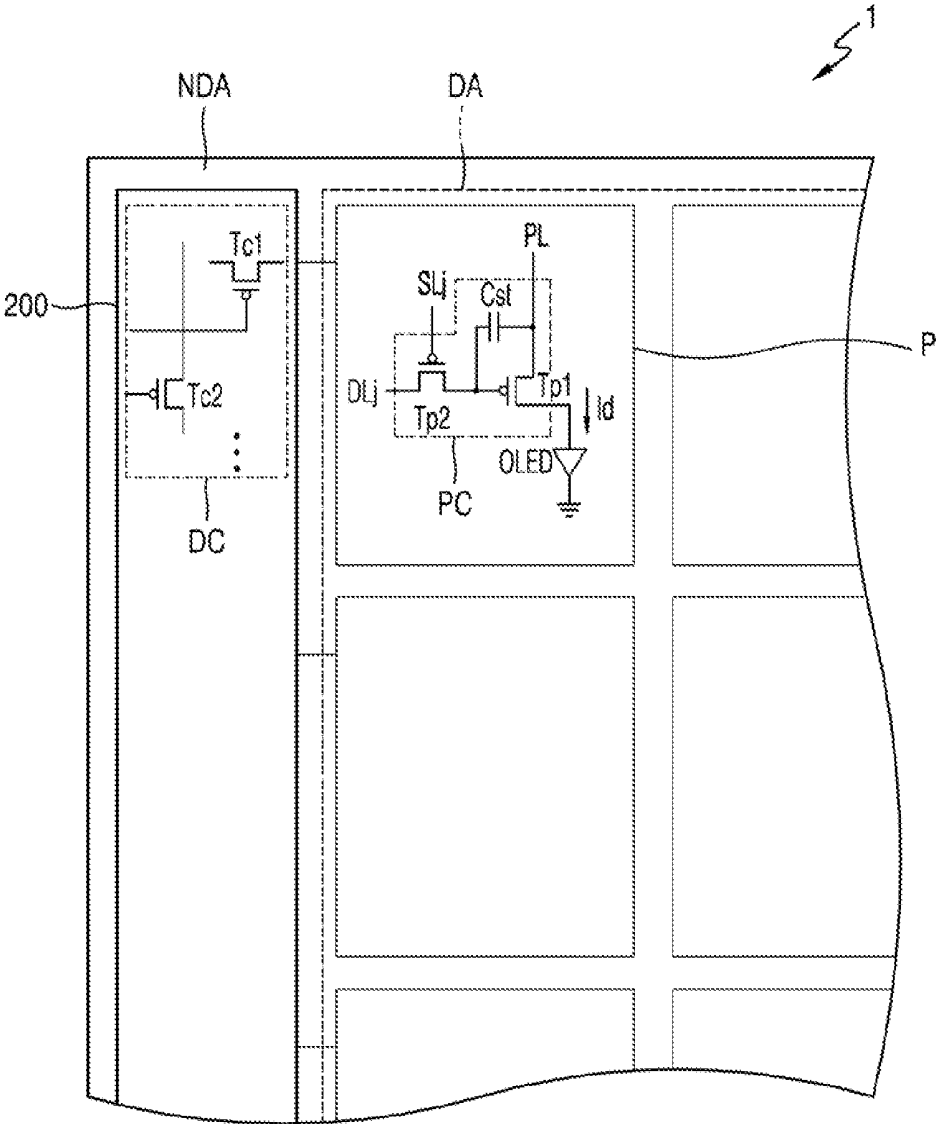

FIG. 3

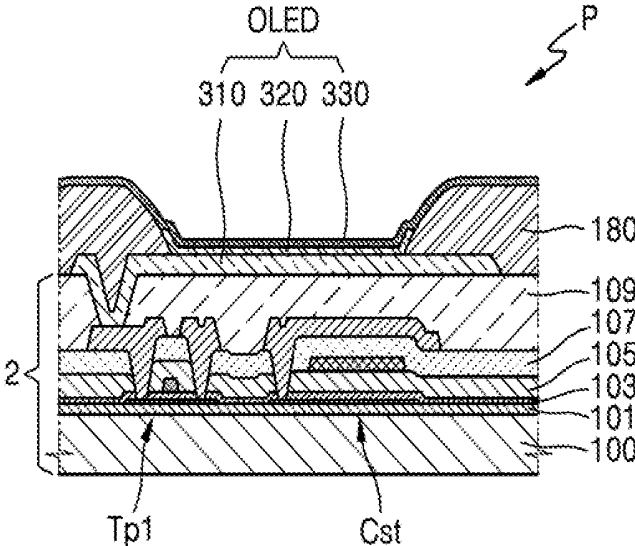

FIG. 4A

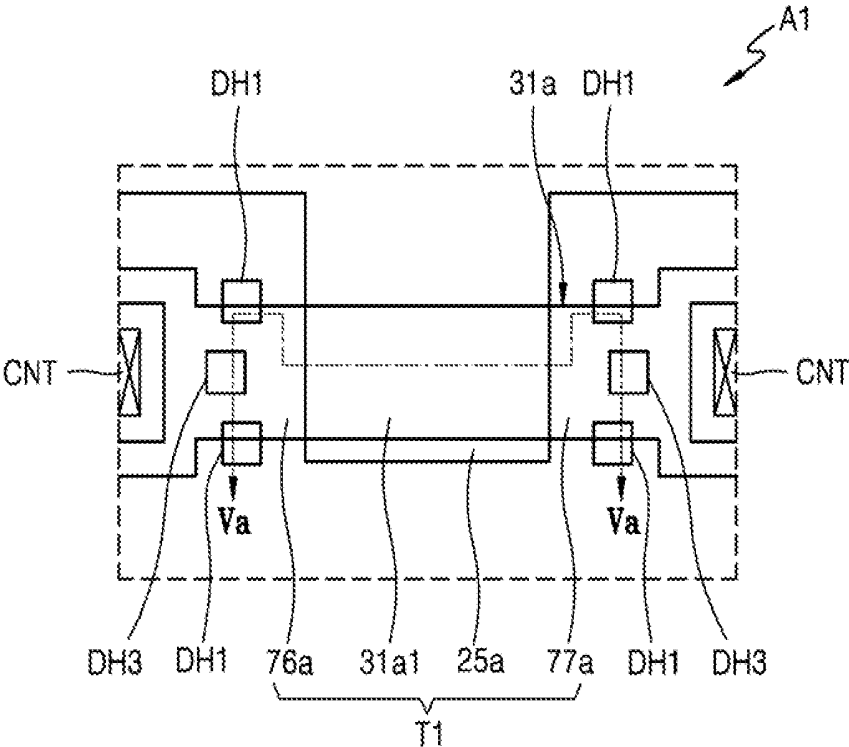

FIG. 4B

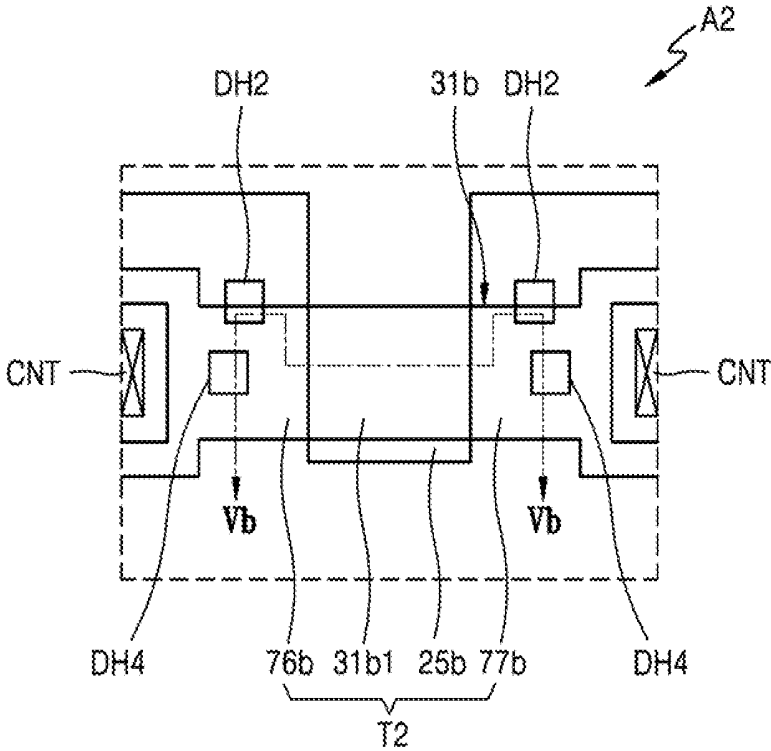

FIG. 5

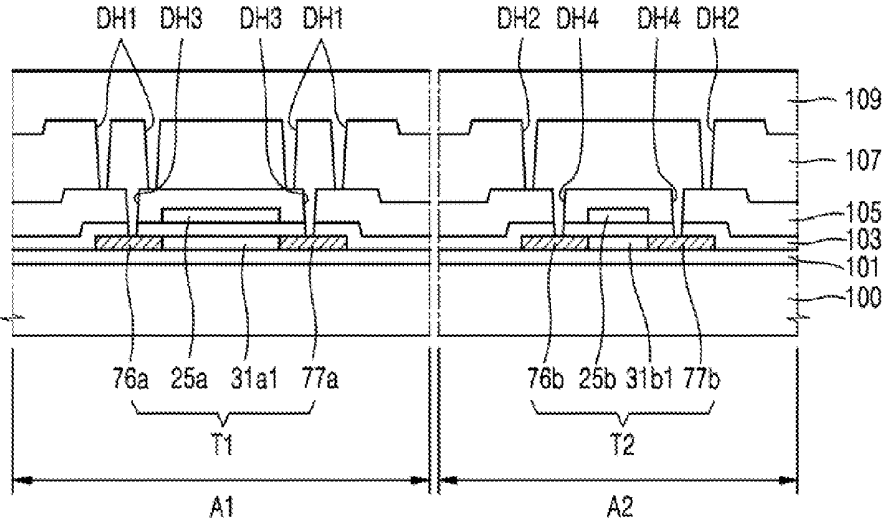

FIG. 6

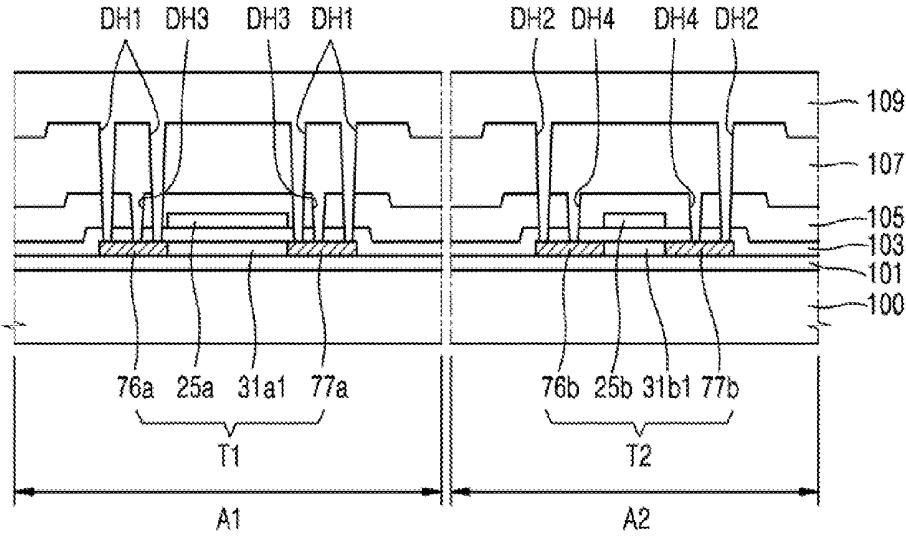

FIG. 7A

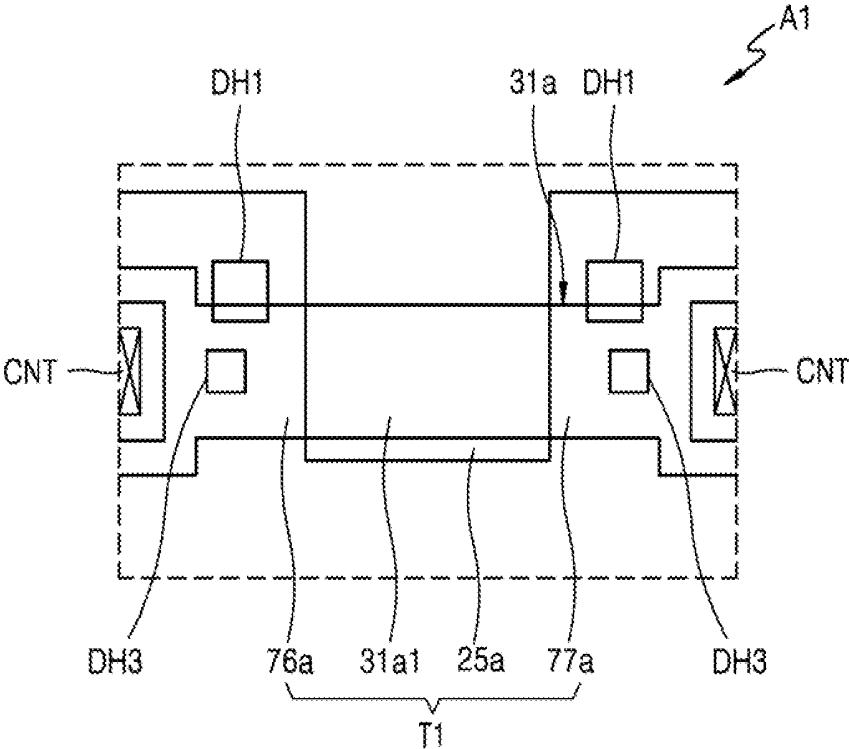

FIG. 7B

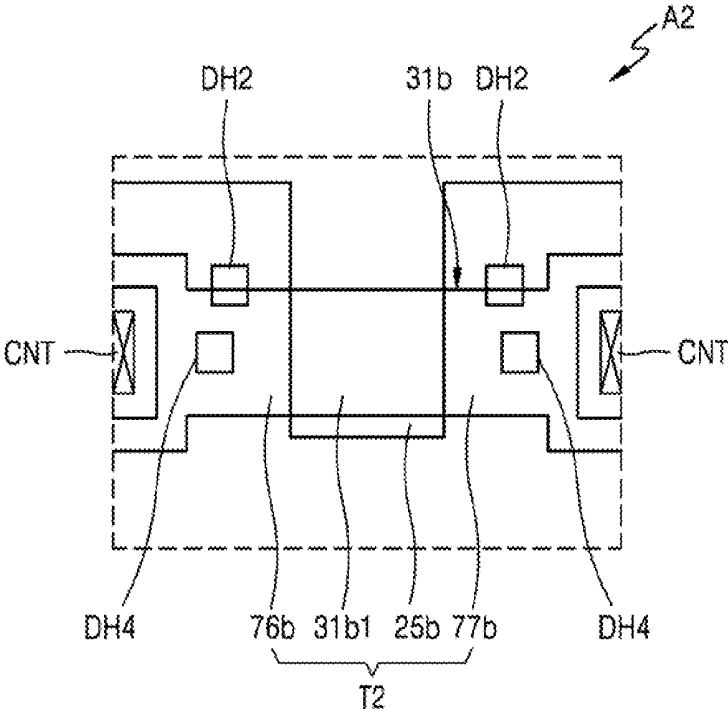

FIG. 8A

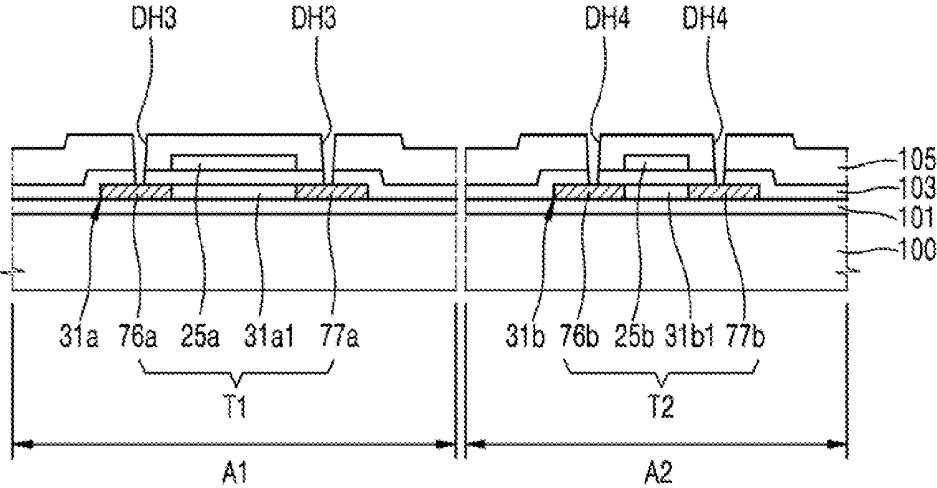

FIG. 8B

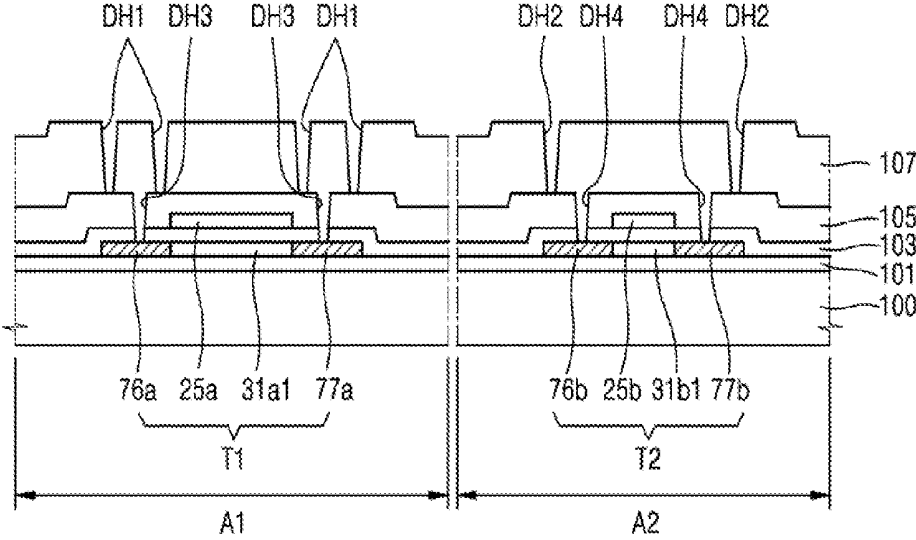

FIG. 8C

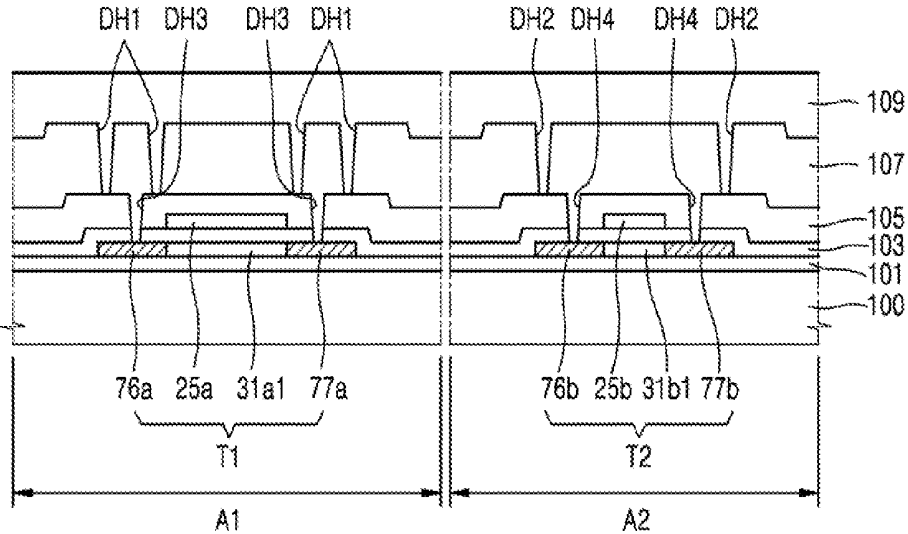

FIG. 9

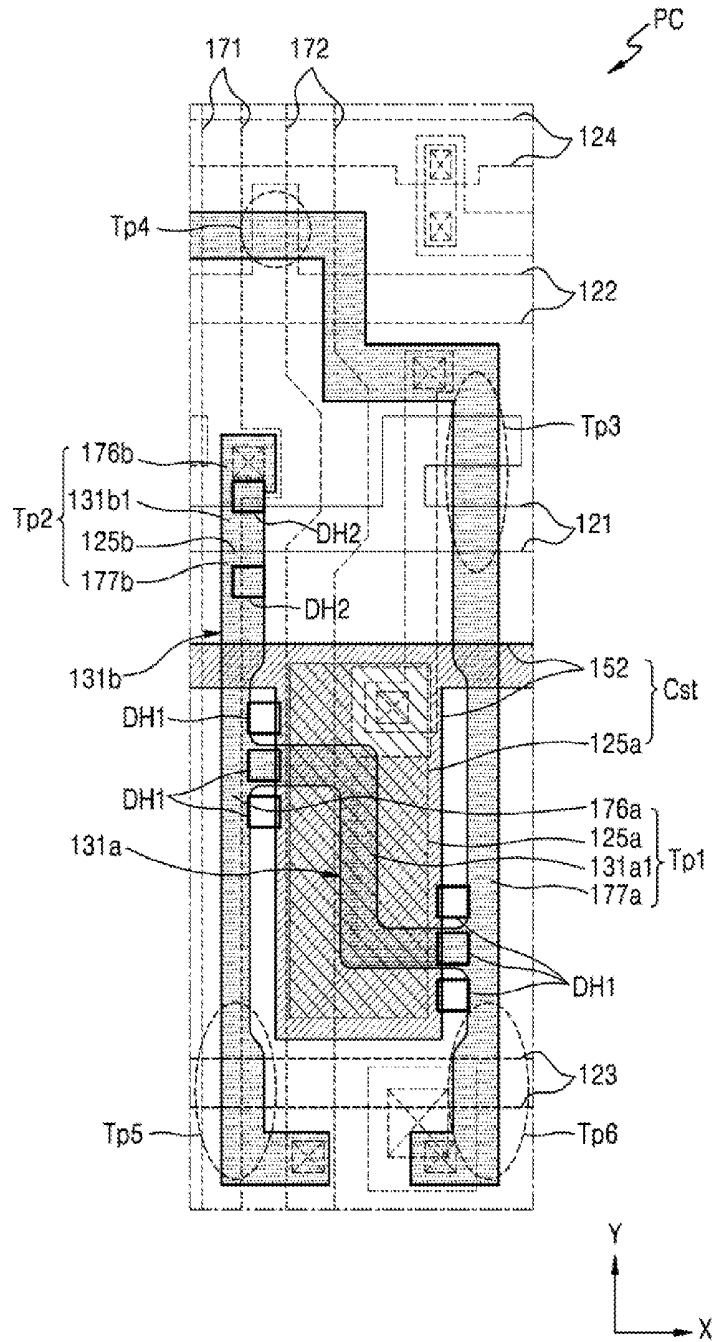

FIG. 10

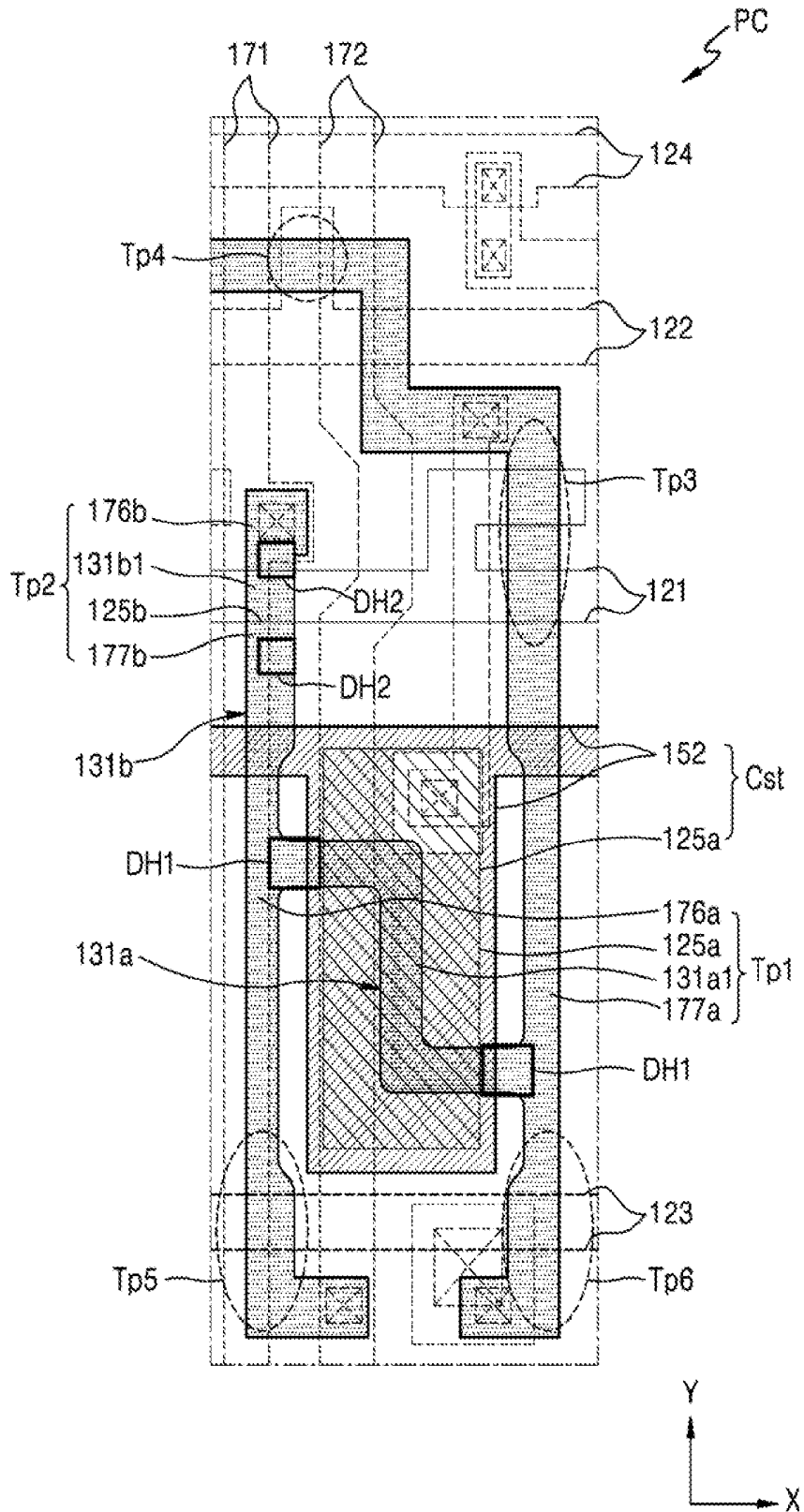

FIG. 11

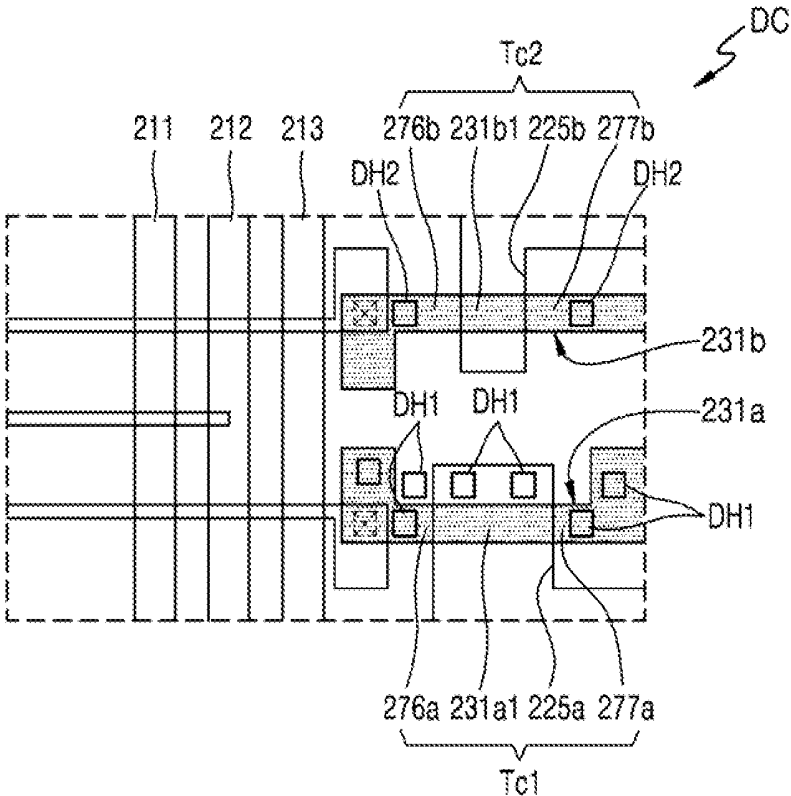

FIG. 12

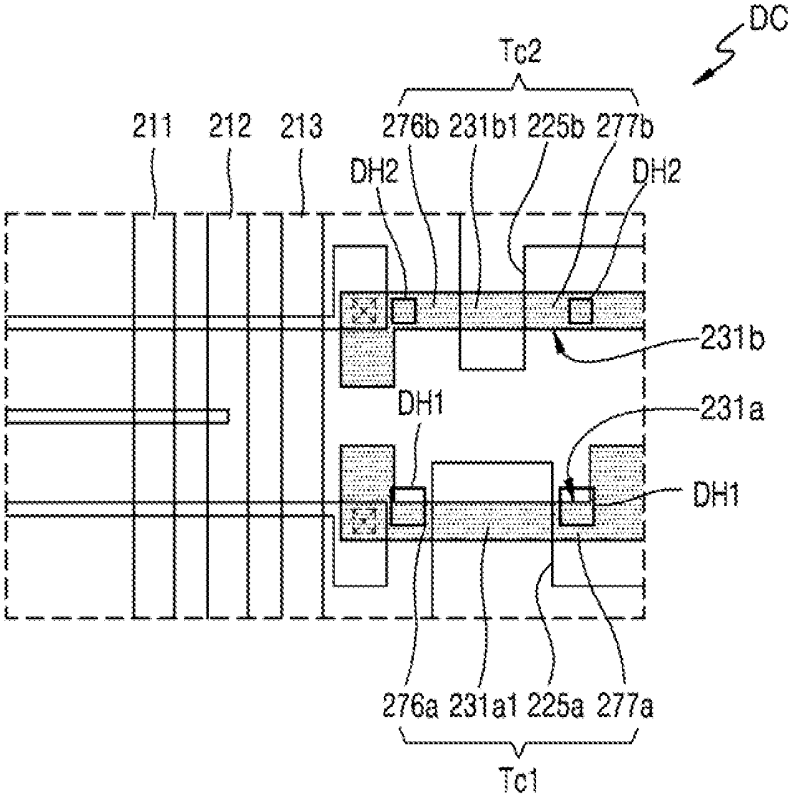

FIG. 13A

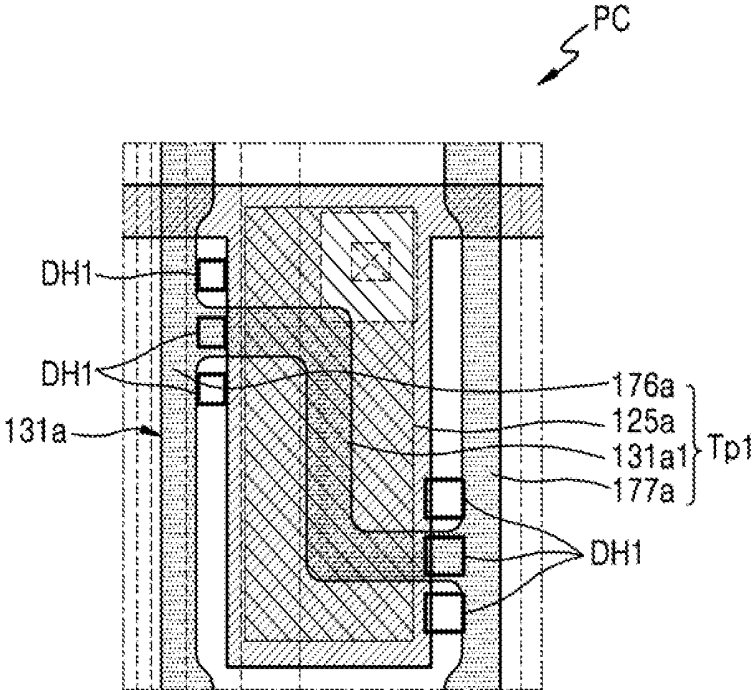

FIG. 13B

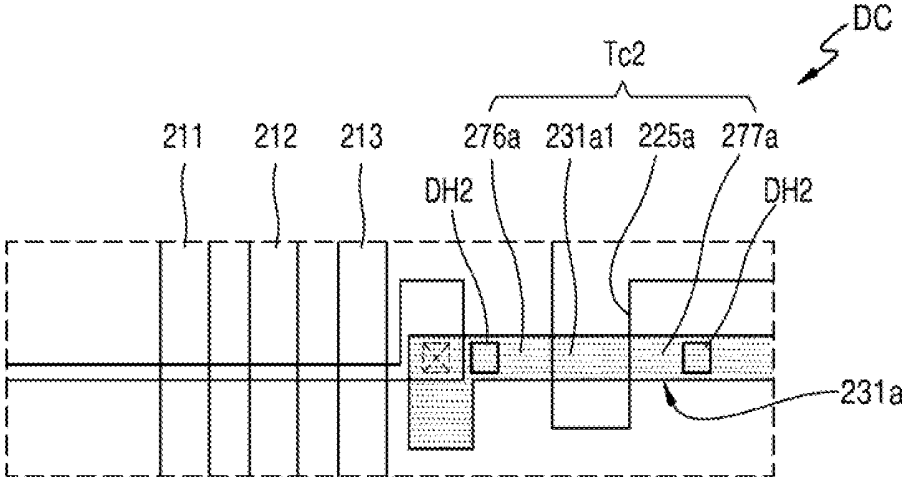

FIG. 14A

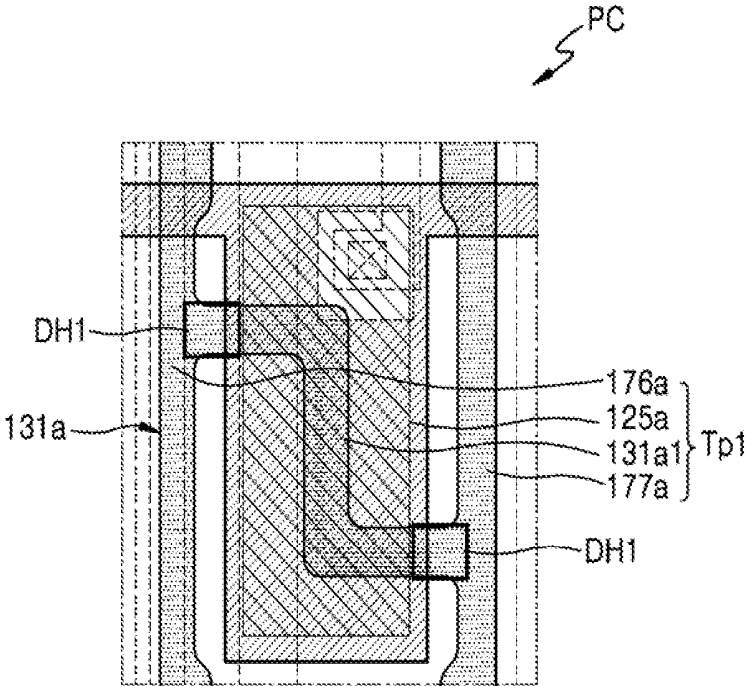
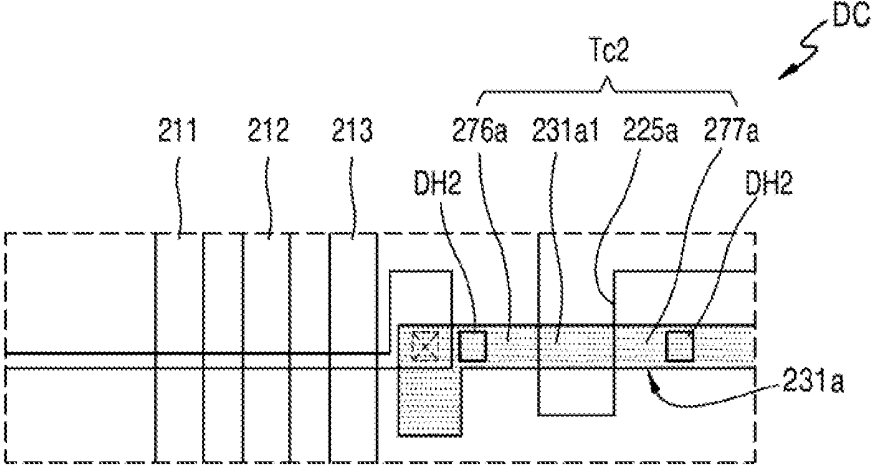

FIG. 14B



**THIN FILM TRANSISTOR AND METHOD
OF MANUFACTURING THE SAME, AND
ORGANIC LIGHT-EMITTING DISPLAY
DEVICE INCLUDING THE SAME**

CROSS-REFERENCE TO RELATED
APPLICATION

[0001] This application claims priority under 35 U.S.C. §119 to Korean Patent Application No. 10-2016-0032914, filed on Mar. 18, 2016, in the Korean Intellectual Property Office, the disclosure of which is incorporated by reference herein in its entirety.

TECHNICAL FIELD

[0002] The present invention relates to an organic light emitting device and a manufacturing method thereof.

DESCRIPTION OF RELATED ART

[0003] Organic light-emitting display devices include a plurality of thin film transistors (TFTs) formed using the same process. Some of the TFTs may serve as switching TFTs operating in response to scan signals. Some of the TFTs may serve as driving TFTs to provide a current flow through an organic light emit device.

SUMMARY

[0004] According to an exemplary embodiment of the present inventive concept, an organic light emitting display device is provided as follows. A first thin film transistor having a first semiconductor pattern is disposed on a substrate. A second thin film transistor having a second semiconductor pattern is disposed on the substrate. An insulating layer covers the first thin film transistor and the second thin film transistor. At least one first dummy hole passing through the insulating layer overlaps the first semiconductor pattern of the first thin film transistor. At least one second dummy hole passing through the insulating layer overlaps the second semiconductor pattern of the second thin film transistor. Numbers or sizes of the at least one first dummy hole and the at least one second dummy hole are different from each other.

[0005] According to an exemplary embodiment of the present inventive concept, a method of manufacturing an organic light emitting device is provided as follows. A first thin film transistor having a first semiconductor pattern and a second thin film transistor having a second semiconductor pattern are formed on a substrate. An insulating layer is formed to cover the first thin film transistor and the second thin film transistor. At least one first dummy hole passing through the insulating layer is formed to overlap the first semiconductor pattern of the first thin film transistor. At least one second dummy hole passing through the insulating layer is formed to overlap the second semiconductor pattern of the second thin film transistor. A heat treatment is performed on the substrate after the forming of the at least one first dummy hole and the at least one second dummy hole. Numbers or sizes of the at least one first dummy hole and at least one second dummy hole are different from each other.

[0006] According to an exemplary embodiment of the present inventive concept, an organic light emitting device is provided as follows. A first thin film transistor having a first semiconductor pattern is disposed on a substrate; A first insulating layer covers the first thin film transistor. A second

insulating layer covers the first insulating layer. A first contact hole passes through the first insulating layer. A source/drain electrode is in contact with the first semiconductor pattern through the first contact hole. A first dummy hole exposes the first semiconductor pattern. The second insulating layer is in contact with the first semiconductor pattern through the first dummy hole.

BRIEF DESCRIPTION OF DRAWINGS

[0007] These and other features of the present invention will become more apparent by describing in detail exemplary embodiments thereof with reference to the accompanying drawings of which:

[0008] FIG. 1 is a plan view illustrating an organic light-emitting display device according to an exemplary embodiment of the present invention;

[0009] FIG. 2 is a plan view illustrating a portion of the organic light-emitting display device of FIG. 1;

[0010] FIG. 3 is a cross-sectional view illustrating one pixel of an organic light-emitting display device;

[0011] FIGS. 4A and 4B are plan views respectively illustrating a first thin film transistor (TFT) and a second TFT of an organic light-emitting display device according to an exemplary embodiment of the present invention;

[0012] FIG. 5 is a cross-sectional view taken along a line Va-Va and a line Vb-Vb of FIGS. 4A and 4B;

[0013] FIG. 6 is a cross-sectional view illustrating a modified embodiment of FIG. 5;

[0014] FIGS. 7A and 7B are plan views respectively illustrating a first region and a second region of an organic light-emitting display device according to an exemplary embodiment of the present invention;

[0015] FIGS. 8A to 8C are cross-sectional views illustrating a process of manufacturing an organic light-emitting display device according to an exemplary embodiment of the present invention;

[0016] FIGS. 9 and 10 are plan views illustrating a pixel circuit of an organic light-emitting display device according to an exemplary embodiment of the present invention;

[0017] FIGS. 11 and 12 are plan views illustrating a driver circuit located in a non-display area of an organic light-emitting display device according to an exemplary embodiment of the present invention;

[0018] FIGS. 13A and 13B are plan views illustrating a pixel circuit located in a display area and a driver circuit located in a non-display area of an organic light-emitting display device according to an exemplary embodiment of the present invention; and

[0019] FIGS. 14A and 14B are plan views illustrating a pixel circuit located in a display area and a driver circuit located in a non-display area of an organic light-emitting display device according to an exemplary embodiment of the present invention.

[0020] Although corresponding plan views and/or perspective views of some cross-sectional view(s) may not be shown, the cross-sectional view(s) of device structures illustrated herein provide support for a plurality of device structures that extend along two different directions as would be illustrated in a plan view, and/or in three different directions as would be illustrated in a perspective view. The two different directions may or may not be orthogonal to each other. The three different directions may include a third direction that may be orthogonal to the two different directions. The plurality of device structures may be integrated in

a same electronic device. For example, when a device structure (e.g., a transistor structure) is illustrated in a cross-sectional view, an electronic device may include a plurality of the device structures (e.g., transistor structures), as would be illustrated by a plan view of the electronic device. The plurality of device structures may be arranged in an array and/or in a two-dimensional pattern.

DETAILED DESCRIPTION OF EXEMPLARY EMBODIMENTS

[0021] Exemplary embodiments of the present invention will be described below in detail with reference to the accompanying drawings. However, the present invention may be embodied in different forms and should not be construed as limited to the embodiments set forth herein. In the drawings, the thickness of layers and regions may be exaggerated for clarity. It will also be understood that when an element is referred to as being “on” another element or substrate, it may be directly on the other element or substrate, or intervening layers may also be present. It will also be understood that when an element is referred to as being “coupled to” or “connected to” another element, it may be directly coupled to or connected to the other element, or intervening elements may also be present. Like reference numerals may refer to the like elements throughout the specification and drawings.

[0022] FIG. 1 is a plan view illustrating an organic light-emitting display device 1 according to an exemplary embodiment of the present invention, FIG. 2 is a plan view illustrating a portion of the organic light-emitting display device 1 of FIG. 1, and FIG. 3 is a cross-sectional view illustrating one pixel of the organic light-emitting display device 1.

[0023] Referring to FIGS. 1 and 2, the organic light-emitting display device 1 includes a display area DA (active area) and a non-display area NDA (dead area). The display area DA includes a plurality of pixels P emitting light. Each pixel P may emit red, green, and blue light, but the present invention is not limited thereto.

[0024] The display area DA includes pixel regions PA. A pixel circuit PC and an organic light-emitting diode (OLED), which is a display element, are disposed in each pixel region PA. The pixel circuit PC may include at least two thin film transistors (TFTs) and at least one storage capacitor. The pixel circuit PC includes a switching TFT Tp2, a driving TFT Tp1, a storage capacitor Cst, and an OLED.

[0025] The switching TFT Tp2 is connected to a scan signal line SLj and a data line DLj. The switching TFT Tp2 transfers a data voltage input from the data line DLj to the driving TFT Tp1 depending on a switching voltage input from the scan signal line SLj.

[0026] The storage capacitor Cst is connected to the switching TFT Tp2 and a power line PL, and stores a voltage corresponding to a difference between a voltage transmitted from the switching TFT Tp2 and a voltage ELVDD supplied to the power line PL.

[0027] The driving TFT Tp1 is connected to the power line PL and the storage capacitor Cst, and may control a driving current Id flowing through the OLED from the driving power line PL in response to a voltage value stored in the storage capacitor Cst. The OLED may emit light having predetermined brightness by using the driving current Id.

[0028] Referring to FIG. 3, the pixel P of FIG. 1 includes an OLED disposed on a TFT substrate 2 including a pixel circuit PC. The OLED includes a pixel electrode 310, an intermediate layer 320 including an organic emission layer, and an opposite electrode 330 facing the pixel electrode 310 with the intermediate layer 320 disposed therebetween.

[0029] The TFT substrate 2 includes a driving TFT Tp1 disposed on a substrate 100, a switching TFT Tp2 (not shown in FIG. 3) electrically connected with the driving TFT Tp1, and a storage capacitor Cst, and includes sequentially stacked insulating layers on the substrate 100.

[0030] In FIG. 3, the TFT substrate 2 denotes a structure including the substrate 100 below the pixel electrode 310. For example, the TFT substrate may include a TFT on the substrate 100. For example, the TFT substrate may further include the insulating layer located below the pixel electrode 310. For example, the TFT substrate may further include a pixel-defining layer 180 covering an end of the pixel electrode 310.

[0031] Referring back to FIGS. 1 and 2, the non-display area NDA may surround the display area DA, and may include a driver 200 for transferring a predetermined signal to a plurality of pixels P provided to the display area DA. In an exemplary embodiment, the driver 200 may be a scan driver.

[0032] A driver circuit DC located in the non-display area NDA may include a plurality of TFTs Tc1 and Tc2. The plurality of TFTs Tc1 and Tc2 may be electrically connected with wirings or different devices and may transfer a scan signal to each pixel.

[0033] FIGS. 4A and 4B are plan views respectively illustrating a first TFT and a second TFT of an organic light-emitting display device according to an exemplary embodiment of the present invention. FIG. 5 is a cross-sectional view taken along a line Va-Va and a line Vb-Vb of FIGS. 4A and 4B, FIG. 6 is a cross-sectional view illustrating a modified embodiment of FIG. 5, and FIGS. 7A and 7B are plan views respectively illustrating a first region and a second region of an organic light-emitting display device according to another embodiment. For convenience of description, FIG. 5 omits layers above a protection layer 109 in an organic light-emitting display device according to an exemplary embodiment of the present invention.

[0034] Referring to FIGS. 4A and 4B, a first TFT T1 is disposed in a first region A1 of an organic light-emitting display device, and a second TFT T2 is disposed in a second region A2 of the organic light-emitting display device. The first TFT T1 includes a first semiconductor pattern 31a including a first channel region 31a1, a first source region 76a and a first drain region 77a disposed at both sides of the first channel region 31a1, and a first gate electrode 25a. The second TFT T2 includes a second semiconductor pattern 31b including a second channel region 31b1, a second source region 76b and a second drain region 77b disposed at both sides of the second channel region 31b1, and a second gate electrode 25b.

[0035] An insulating layer covers the first TFT T1 and the second TFT T2. The first TFT T1 and the second TFT T2 may have different characteristics via a dummy hole passing through the insulating layer. Hereinafter, for convenience of description, description is made according to a stacking sequence with reference to FIGS. 4A, 4B and 5.

[0036] Referring to FIGS. 4A, 4B and 5, the substrate 100 may include a glass material, a metallic material, or a plastic

material such as polyethylene terephthalate (PET), polyethylene naphthalate (PEN), and polyimide.

[0037] A buffer layer **101** may be disposed on the substrate **100**, and may include an oxide layer such as SiO_x and/or a nitride layer such as SiN_x.

[0038] The first and second semiconductor patterns **31a** and **31b** are disposed on the buffer layer **101**. The first and second semiconductor patterns **31a** and **31b** include polycrystalline silicon. The first semiconductor pattern **31a** includes the first channel region **31a1**, the first source region **76a** and the first drain region **77a** doped with impurities of higher concentration than that of the first channel region **31a1**. The second semiconductor pattern **31b** includes the second channel region **31b1**, the second source region **76b** and the second drain region **77b** doped with impurities of higher concentration than that of the second channel region **31b1**. The impurities may change depending on a kind of a TFT, and N-type impurities or P-type impurities may be used.

[0039] A gate insulating layer **103** is disposed on the first and second semiconductor patterns **31a** and **31b**. The gate insulating layer **103** may include a single-layered or multi-layered thin film including an inorganic material including an oxide layer such as SiO_x and/or a nitride layer such as SiN_x, or an organic material. Though FIG. 5 illustrates a case where the gate insulating layer **103** entirely covers the substrate **100**, the present invention is not limited thereto. For example, the gate insulating layer **103** may have the same pattern as patterns of the first and second gate electrodes **25a** and **25b** depending on a patterning process.

[0040] The first and second gate electrodes **25a** and **25b** overlap the first and second channel regions **31a1** and **31b1**, respectively, with the gate insulating layer **103** disposed therebetween. The first and second gate electrodes **25a** and **25b** may include a metallic material such as Al and Cu, but the present invention is not limited thereto.

[0041] An insulating layer **107** covers the first and second TFTs **T1** and **T2** on the substrate **100**. The insulating layer **107** may include an inorganic material including an oxide layer such as SiO_x, an oxynitride layer such as SiON, and/or a nitride layer such as SiN_x. The present invention is not limited thereto. For example, the insulating layer **107** may include an acryl-based organic material or an organic insulating layer such as benzocyclobutene (BCB).

[0042] A first dummy hole **DH1** and a second dummy hole **DH2** pass through the insulating layer **107**. The first dummy hole **DH1** is adjacent to the first TFT **T1**, and the second dummy hole **DH2** is adjacent to the second TFT **T2**.

[0043] The number of first dummy holes **DH1** and the number of second dummy holes **DH2** are different from each other. In an exemplary embodiment, the number of first dummy holes **DH1** is greater than the number of second dummy holes **DH2**.

[0044] The first and second dummy holes **DH1** and **DH2** may adjust characteristics of the first and second TFTs **T1** and **T2**. Hydrogen ions exist at the interfaces between the gate insulating layer **103** and the first semiconductor pattern **31a** and between the gate insulating layer **103** and the second semiconductor patterns **31b**. The hydrogen ions may evaporate via the first and second dummy holes **DH1** and **DH2** in the manufacturing of the first and second TFTs **T1** and **T2** are manufactured.

[0045] When the number of first dummy holes **DH1** is greater than the number of second dummy holes **DH2**, larger

amount of hydrogen ions evaporate via the first dummy hole **DH1** than the second dummy holes **DH2**, so that the mobility of the first TFT **T1** becomes less than the mobility of the second TFT **T2**. Therefore, the characteristics of the first and second TFTs **T1** and **T2** may be adjusted by differing the numbers of first and second dummy holes **DH1** and **DH2** as described above.

[0046] An interlayer insulating layer **105** is disposed between the first TFT **T1** and the insulating layer **107** and the second TFT **T2** and the insulating layer **107**. Contact holes **CNT** connecting the first and second source regions **76a** and **76b** and the first and second drain regions **77a** and **77b** of the first and second TFTs **T1** and **T2** with wirings may be located in the interlayer insulating layer **105**.

[0047] The interlayer insulating layer **105** may include a third dummy hole **DH3** and a fourth dummy hole **DH4**. For example, the third and fourth dummy holes **DH3** and **DH4** may penetrate the interlayer insulating layer **105**.

[0048] The third and fourth dummy holes **DH3** and **DH4** may expose the first and second semiconductor patterns **31a** and **31b** respectively, and evaporate hydrogen contained in the first and second semiconductor patterns **31a** and **31b** in the manufacturing of the first and second TFTs **T1** and **T2**.

[0049] The interlayer insulating layer **105** may include an inorganic material including an oxide layer such as SiO_x, an oxynitride layer such as SiON, or a nitride layer such as SiN_x, and include a single layer or a multi-layer.

[0050] The protection layer **109** may be disposed on the insulating layer **107**. The protection layer **109** may serve to protect the first and second TFTs **T1** and **T2**. The protection layer **109** may also serve as a planarization layer having a flat upper surface. The protection layer **109** may include an acryl-based organic material or an organic insulating layer such as benzocyclobutene (BCB). A portion of the protection layer **109** fills the first and second dummy holes **DH1** and **DH2**.

[0051] The first and second dummy holes **DH1** and **DH2** may overlap the third and fourth dummy holes **DH3** and **DH4**. The present invention is not limited thereto. For example, as shown in FIG. 5, the first and second dummy holes **DH1** and **DH2** need not overlap each other. In this case, hydrogen of the first and second semiconductor patterns **31a** and **31b** may pass through the interlayer insulating layer **105** through diffusion and evaporate via the first and second dummy holes **DH1** and **DH2**.

[0052] In FIG. 6, the first and second dummy holes **DH1** and **DH2** may extend toward the substrate **100** and pass through the interlayer insulating layer **105**, the insulating layer **107** and the gate insulating layer **103**. In this case, the first and second dummy holes **DH1** and **DH2** may extend up to the first and second semiconductor patterns **31a** and **31b** depending on the locations of the first and second dummy holes **DH1** and **DH2**.

[0053] According to an exemplary embodiment described with reference to FIGS. 4A and 4B, the number of first dummy holes **DH1** and the number of second dummy holes **DH2** are different from each other. The present invention is not limited thereto.

[0054] In an exemplary embodiment, as illustrated in FIGS. 7A and 7B, the size of the first dummy hole **DH1** and the size of the second dummy hole **DH2** may be different from each other. Since evaporation of hydrogen is actively performed via the large-sized first dummy hole **DH1** compared to the relatively small-sized second dummy hole **DH2**,

the characteristics of the first and second TFTs T1 and T2 may be controlled differently.

[0055] The controlling of the characteristics of the first and second TFTs T1 and T2 using the first and second dummy holes DH1 and DH2 is described below with reference to FIGS. 8A to 8C.

[0056] FIGS. 8A to 8C are cross-sectional views illustrating a process of manufacturing an organic light-emitting display device according to an exemplary embodiment.

[0057] Referring to FIG. 8A, the first and second TFTs T1 and T2 are formed on the substrate 100.

[0058] The buffer layer 101 is formed on the substrate 100, and the first semiconductor pattern 31a located in the first region A1 of the substrate 100 and the second semiconductor pattern 31b located in the second region A2 of the substrate 100 are formed by forming a semiconductor layer (not shown) on the buffer layer 101 and patterning the semiconductor layer. The substrate 100 and the buffer layer 101 may include the above-described material. The buffer layer 101 may be omitted depending on a material forming the substrate 100 and a process.

[0059] The first and second semiconductor patterns 31a and 31b may include polysilicon. According to an exemplary embodiment, the polysilicon may be formed by crystallizing amorphous silicon. Various crystallizing methods such as a rapid thermal annealing (RTA) method, a solid phase crystallization (SPC) method, an excimer laser annealing (ELA) method, a metal induced crystallization (MIC) method, a metal induced lateral crystallization (MILC) method, or a sequential lateral solidification (SLS) method may be used.

[0060] The gate insulating layer 103 is formed on the first and second semiconductor patterns 31a and 31b. Also, the first and second gate electrodes 25a and 25b are formed by forming a metallic layer (not shown) on the gate insulating layer 103 and patterning the metallic layer. The gate insulating layer 103 may include a single-layered or multi-layered thin film including an inorganic material including an oxide layer such as SiO_x or a nitride layer such as SiN_x, or an organic material. The gate insulating layer 103 may be formed by using a deposition method such as a plasma-enhanced chemical vapor deposition (PECVD) method, an atmospheric pressure CVD (APCVD) method, and a low pressure CVD (LPCVD) method. The first and second gate electrodes 25a and 25b may include a metallic material such as Al and Cu, and include a single layer or a multi-layer.

[0061] The first and second source regions 76a and 76b and the first and second drain regions 77a and 77b are formed by doping the first and second semiconductor patterns 31a and 31b with impurities. In this case, the first and second gate electrodes 25a and 25b may serve as a self-aligned mask for forming the source regions 76a and 76b and the drain regions 77a and 77b.

[0062] The interlayer insulating layer 105 is formed to cover the first and second gate electrodes 25a and 25b. The interlayer insulating layer 105 may include an inorganic material including an oxide layer such as SiO_x, an oxynitride layer such as SiON, or a nitride layer such as SiN_x, and include a single layer or a multi-layer.

[0063] Though not shown, contact holes CNT (see FIGS. 4A and 4B) for electric connection between wirings and the first and second TFTs T1 and T2 are formed in the interlayer insulating layer 105.

[0064] The third and fourth dummy holes DH3 and DH4 may be formed in the interlayer insulating layer 105. For example, the third and fourth dummy holes DH3 and DH4 may penetrate the interlayer insulating layer 105 and the gate insulating layer 103 to expose the first source region 76a and the first drain region 77a. A first annealing process, for example, a heat-treatment process, may be applied to the resulting structure of FIG. 8A to evaporate hydrogen contained in the first and second semiconductor patterns 31a and 31b via the third and fourth dummy holes DH3 and DH4.

[0065] Referring to FIG. 8B, the insulating layer 107 is formed on the interlayer insulating layer 105. The insulating layer 107 may include an inorganic material including an oxide layer such as SiO_x, an oxynitride layer such as SiON, or a nitride layer such as SiN_x. The present invention is not limited thereto. For example, the insulating layer 107 may include an acryl-based organic material or an organic insulating layer such as BCB. The insulating layer 107 may include a single layer or a multi-layer including the above-described materials.

[0066] The first and second dummy holes DH1 and DH2 are formed in the insulating layer 107. For example, the first and second dummy holes DH1 and DH2 may penetrate the insulating layer 107 to expose the interlayer insulating layer 105. The number of first dummy holes DH1 and the number of second dummy holes DH2 are different from each other. For example, the number of first dummy holes DH1 may be greater than the number of second dummy holes DH2.

[0067] After the formation of the first and second dummy holes DH1 and DH2 in the insulating layer 107, a second annealing process (heat-treatment process) is performed on the resulting structure of FIG. 8B to evaporate hydrogen ions from the first and second semiconductor patterns 31a and 31b via the first and second dummy holes DH1 and DH2. Since the number of first dummy holes DH1 is greater than the number of second dummy holes DH2, a relatively large amount of hydrogen evaporates via the first dummy holes DH1, so that mobility of the first TFT T1 becomes less than mobility of the second TFT T2. For example, the first TFT T1 and the second TFT T2 have different characteristics when the first and second TFT T1 and T2 are formed using the same process.

[0068] Referring to FIG. 8C, the protection layer 109 is formed on the insulating layer 107. The protection layer 109 may include an acryl-based organic material or an organic insulating layer such as benzocyclobutene (BCB).

[0069] According to an exemplary embodiment, the first and second TFTs T1 and T2 are formed via the same process, but may have different characteristics by differing the numbers or the sizes of the first and second dummy holes DH1 and DH2.

[0070] In an exemplary embodiment, the numbers and the sizes of third and fourth dummy holes DH3 and DH4 passing through the interlayer insulating layer 105 may be different from each other to control the characteristics of the first and second TFTs T1 and T2. For example, the characteristics of the first and second transistors TFTs T1 and T2 may be independently controlled using the same process to form the first and second transistors TFTs T1 and T2 by differing the numbers and the sizes of the first and second dummy holes DH1 and DH2 or the numbers and the sizes of the third and fourth dummy holes DH3 and DH4.

[0071] In an exemplary embodiment, FIGS. 8A to 8C describe a process of manufacturing a TFT substrate of an organic light-emitting display device corresponding to FIGS. 4A and 4B. The present invention is not limited thereto. The TFT substrate of the organic light-emitting display device described with reference to FIGS. 6, 7A, and 7B is also manufactured according to a process similar to the process described with reference to FIGS. 8A to 8C with the only difference being in differing the depths of the first and second dummy holes DH1 and DH2 or differing the sizes of the first and second dummy holes DH1 and DH2 instead of the numbers of first and second dummy holes DH1 and DH2.

[0072] FIGS. 9 and 10 are plan views illustrating a pixel circuit of an organic light-emitting display device according to an exemplary embodiment.

[0073] Referring to FIG. 9, a pixel P includes a scan signal line 121, a previous scan signal line 122, an emission control line 123, and an initialization voltage line 124 extending along an X-direction, and a data line 171 and a driving power line 172 extending along a Y-axis direction.

[0074] The pixel P may further include a driving TFT Tp1, a switching TFT Tp2, a compensation TFT Tp3, an initialization TFT Tp4, an operation control TFT Tp5, an emission control TFT Tp6, and a storage capacitor Cst.

[0075] A driving semiconductor pattern 131a includes a driving channel region 131a1, a driving source region 176a and a driving drain region 177a located at both sides of the driving channel region 131a1 and including impurities of higher concentration than that of the driving channel region 131a1. The driving channel region 131a1 overlaps a driving gate electrode 125a. A gate insulating layer is disposed between the driving channel region 131a1 and the driving gate electrode 125a.

[0076] A switching semiconductor pattern 131b includes a switching channel region 131b1, a switching source region 176b and a switching drain region 177b located at both sides of the switching channel region 131b1 and including impurities of higher concentration than that of the switching channel region 131b1. The switching channel region 131b1 overlaps a switching gate electrode 125b. A gate insulating layer is disposed between the switching channel region 131b1 and the switching gate electrode 125b. In an exemplary embodiment, the gate insulating layer of the driving TFT Tp1 and the gate insulating layer of the switching TFT Tp2 may be formed using the same process, and may be formed of the same material.

[0077] A channel length of the driving channel region 131a1 may be greater than that of the switching channel region 131b1. For example, a long channel length may be formed in a narrow space by bending the driving semiconductor pattern 131a to include a plurality of bent portions having shapes such as an alphabet L or S, or Ω .

[0078] The storage capacitor Cst may be disposed to overlap the driving TFT Tp1. A sufficient storage capacitance may be secured at even a high resolution by forming the storage capacitor Cst to overlap the driving TFT Tp1.

[0079] The storage capacitor Cst includes a first electrode 125a and a second electrode 152 overlapping each other with a dielectric insulating layer disposed therebetween. The first electrode 125a also serves as a driving gate electrode of the driving TFT Tp1. For example, the driving channel region 131a1 is a portion of the driving semiconductor pattern 131 which overlaps the first electrode 125a.

[0080] The driving TFT Tp1 and the switching TFT Tp2 are covered with an insulating layer, and have different characteristics due to the first dummy hole DH1 and the second dummy hole DH2 penetrating the insulating layer.

[0081] For example, the number of first dummy holes DH1 adjacent to the driving TFT Tp1 is greater than the number of second dummy holes DH2 adjacent to the switching TFT Tp2. Therefore, hydrogen ions contained in the driving semiconductor pattern 131a may evaporate more than hydrogen ions contained in the switching semiconductor pattern 131b, so that the driving TFT Tp1 and the switching TFT Tp2 have different characteristics as described with reference to FIGS. 4A to 8C.

[0082] Since hydrogen ions of the driving TFT Tp1, like the first TFT T1, evaporate much, mobility reduces and an I—V curve has a gentle slope before a threshold voltage. That is, a driving (DR) range increases and thus abundant gray scales may be expressed. In contrast, since hydrogen ions of the switching TFT Tp2, like the second TFT T2, evaporate less, the switching TFT Tp2 has a good on/off characteristic and thus may have a characteristic advantageous to a high speed operation.

[0083] In FIG. 9, the numbers of first and second dummy holes DH1 and DH2 are different to control the characteristics of the driving TFT Tp1 and the switching TFT Tp2 independently using the same process. The present invention is not limited thereto. For example, as illustrated in FIG. 10, the sizes of the first and second dummy holes DH1 and DH2 are different to control the characteristics of the driving TFT Tp1 and the switching TFT Tp2 independently using the same process.

[0084] FIGS. 11 and 12 are plan views illustrating a driver circuit DC located in a non-display area of an organic light-emitting display device according to an exemplary embodiment.

[0085] Referring to FIG. 11, the driver circuit DC is located in a non-display area NDA (see FIG. 2), and includes wirings 211, 212, and 213, and TFTs Tc1 and Tc2 connected to the wirings. Hereinafter, for convenience of description, one of the TFTs Tc1 and Tc2 is referred to as a TFT Tc1 for a first driver circuit, and the other is referred to as a TFT Tc2 for a second driver circuit.

[0086] A semiconductor pattern 231a of the TFT Tc1 for the first driver circuit includes a channel region 231a1, a source region 276a and a drain region 277a located at both sides of the channel region 231a1 and including impurities of higher concentration than that of the channel region 231a1. The channel region 231a1 overlaps a gate electrode 225a. A gate insulating layer may be disposed between the channel region 231a1 and the gate electrode 225a.

[0087] A semiconductor pattern 231b of the TFT Tc2 for the second driver circuit includes a channel region 231b1, a source region 276b and a drain region 277b located at both sides of the channel region 231b1 and including impurities of higher concentration than that of the channel region 231b1. The channel region 231b1 overlaps a gate electrode 225b. A gate insulating layer may be disposed between the channel region 231b1 and the gate electrode 225b. In an exemplary embodiment, the gate insulating layer of the first driver circuit and the gate insulating layer of the second driver circuit may be formed using the same process.

[0088] An insulating layer covers the TFTs Tc1 and Tc2 for the first and second driver circuits, and the number of

first dummy holes DH1 and the number of second dummy holes DH2 provided to the insulating layer are different from each other.

[0089] As an area occupied by a display area DA increases and an area occupied by a non-display area NDA gradually reduces in the organic light-emitting display device 1 (see FIG. 1), design of the driver circuit DC is complicated, and some of TFTs reduce in their size, and functionally different characteristics of the TFTs are required. Therefore, as illustrated in FIG. 11, the TFT Tc1 for the first driver circuit and the TFT Tc2 for the second driver circuit may have different characteristics by differing the number of first dummy holes DH1 adjacent to the TFT Tc1 for the first driver circuit from the number of second dummy holes DH2 adjacent to the TFT Tc2 for the second driver circuit.

[0090] In an exemplary embodiment, the number of first dummy holes DH1 may be greater than the number of second dummy holes DH2. Therefore, the large amount of hydrogen ions contained in the semiconductor pattern 231a of the TFT Tc1 for the first driver circuit evaporate like those contained in the first TFT T1, but the small amount of hydrogen ions contained in the semiconductor pattern 231b of the TFT Tc2 for the second driver circuit evaporate like those contained in the second TFT T2. Since the amounts of evaporated hydrogen ions are different, the TFTs Tc1 and Tc2 for the first and second driver circuits which are manufactured using the same process have different characteristics, as described with reference to FIGS. 4A to 8C.

[0091] In FIG. 11, the number of first dummy holes DH1 is different from the number of second dummy holes DH2. The present invention is not limited thereto. For example, as illustrated in FIG. 12, the TFTs Tc1 and Tc2 for the first and second driver circuits may have different characteristics by differing the sizes of the first and second dummy holes DH1 and DH2 in the manufacturing of the TFTs Tc1 and Tc2 for the first and second driver circuits using the same process.

[0092] FIGS. 13A and 13B, 14A and 14B are plan views illustrating a pixel circuit PC located in a display area and a driver circuit DC located in a non-display area of an organic light-emitting display device according to an exemplary embodiment.

[0093] Referring to FIGS. 13A and 13B, each of the pixel circuit PC and the driver circuit DC includes a plurality of TFTs. For convenience of description, FIG. 13A illustrates a driving TFT Tp1 of the pixel circuit PC, and FIG. 13B illustrates a TFT Tc2 for a first driver circuit of the driver circuit DC.

[0094] A driving semiconductor pattern 131a of the driving TFT Tp1 includes a driving channel region 131a1, a driving source region 176a and a driving drain region 177a located at both sides of the driving channel region 131a1 and including impurities of higher concentration than that of the driving channel region 131a1. The driving channel region 131a1 overlaps a driving gate electrode 125a with a gate insulating layer disposed therebetween.

[0095] A semiconductor pattern 231a of the TFT Tc2 for the first driver circuit includes a channel region 231a1, a source region 276a and a drain region 277a located at both sides of the channel region 231a1 and including impurities of higher concentration than that of the channel region 231a1. The channel region 231a1 overlaps a gate electrode 225a with a gate insulating layer disposed therebetween. In an exemplary embodiment, the gate insulating layer of the

driving TFT Tp1 and the gate insulating layer of TFT Tc2 for the first driver circuit may be formed using the same process **[0096]** An insulating layer covers the driving TFT Tp1 and the TFT Tc2 for the first driver circuit, and the number of first dummy holes DH1 penetrating the insulating layer is different from the number of second dummy holes DH2 penetrating the insulating layer.

[0097] According to an exemplary embodiment, the number of first dummy holes DH1 adjacent to the driving TFT Tp1 is greater than the number of second dummy holes DH2 adjacent to the TFT Tc2 for the first driver circuit. Therefore, the large amount of hydrogen ions contained in the semiconductor pattern 131a of the driving TFT Tp1 evaporate like those contained in the first TFT T1, but the small amount of hydrogen ions contained in the semiconductor pattern 231a of the TFT Tc2 for the first driver circuit evaporate like those contained in the second TFT T2.

[0098] The driving TFT Tp1 and the TFT Tc2 for the first driver circuit may have different characteristics by differing the numbers of first and second dummy holes DH1 and DH2 in the manufacturing of the driving TFT Tp1 and the TFT Tc2 using the same process, which is described with reference to FIGS. 4A to 8C.

[0099] In FIGS. 13A and 13B, the number of first dummy holes DH1 is different from the number of second dummy holes DH2. The present invention is not limited thereto. For example, as illustrated in FIGS. 14A and 14B, the driving TFT Tp1 and the TFT Tc2 for the first driver circuit may have different characteristics in the manufacturing of the driving TFT Tp1 and the TFT Tc2 for the first driver circuit by differing the sizes of the first and second dummy holes DH1 and DH2 using the same process.

[0100] While the present invention has been shown and described with reference to exemplary embodiments thereof, it will be apparent to those of ordinary skill in the art that various changes in form and detail may be made therein without departing from the spirit and scope of the present invention as defined by the following claims.

What is claimed is:

1. An organic light emitting display device comprising:
 - a substrate;
 - a first thin film transistor having a first semiconductor pattern disposed on the substrate;
 - a second thin film transistor having a second semiconductor pattern disposed on the substrate;
 - an insulating layer covering the first thin film transistor and the second thin film transistor;
 - at least one first dummy hole passing through the insulating layer and overlapping the first semiconductor pattern of the first thin film transistor; and
 - at least one second dummy hole passing through the insulating layer and overlapping the second semiconductor pattern of the second thin film transistor,
 wherein numbers or sizes of the at least one first dummy hole and the at least one second dummy hole are different from each other.
2. The organic light emitting display device of claim 1, further comprising:
 - a protection layer disposed on the insulating layer,
 wherein a portion of the protection layer fills the at least one first dummy hole and the at least one second dummy hole.

3. The organic light emitting display device of claim 2, wherein the protection layer comprises an organic insulating material.
4. The organic light emitting display device of claim 1, further comprising:
an interlayer insulating layer disposed between the first thin film transistor and the insulating layer and between the second thin film transistor and the insulating layer.
5. The organic light emitting display device of claim 4, wherein the at least one first dummy hole and the at least one second dummy hole further pass through the interlayer insulating layer, extending toward the substrate.
6. The organic light emitting display device of claim 4, further comprising:
a third dummy hole passing through the interlayer insulating layer and overlapping the first semiconductor pattern; and
a fourth dummy hole passing through the interlayer insulating layer and overlapping the second semiconductor pattern.
7. The organic light emitting display device of claim 1, wherein each of the first semiconductor pattern of the first thin film transistor and the second semiconductor pattern of the second thin film transistor comprises polysilicon.
8. The organic light emitting display device of claim 1, wherein the substrate comprises a display area comprising a plurality of pixels, and wherein the first thin film transistor and the second thin film transistor are located in at least one of the plurality of pixels.
9. The organic light emitting display device of claim 8, wherein the first thin film transistor comprises a driving thin film transistor, and the second thin film transistor comprises a switching thin film transistor.
10. The organic light emitting display device of claim 9, wherein a number or a size of the at least one first dummy hole is greater than a number or a size of the at least one second dummy hole.
11. The organic light emitting display device of claim 1, wherein the substrate comprises a display area comprising a plurality of pixel regions and a non-display area surrounding the display area, and wherein the first thin film transistor is located in the pixel region, and the second thin film transistor is located in the non-display area.
12. The organic light emitting display device of claim 1, wherein the substrate comprises a display area comprising a plurality of pixel regions and a non-display area surrounding the display area, and wherein the first thin film transistor and the second thin film transistor are located in the non-display area.
13. The organic light emitting display device of claim 12, wherein a channel length of the first thin film transistor is different from a channel length of the second thin film transistor.
14. The organic light-emitting display device of claim 1, further comprising:
a display element disposed on the first and second thin film transistors.
15. A method of manufacturing an organic light emitting device, the method comprising:
forming a first thin film transistor having a first semiconductor pattern and a second thin film transistor having a second semiconductor pattern on a substrate;
forming an insulating layer covering the first thin film transistor and the second thin film transistor;
forming at least one first dummy hole passing through the insulating layer and overlapping the first semiconductor pattern of the first thin film transistor;
forming at least one second dummy hole passing through the insulating layer and overlapping the second semiconductor pattern of the second thin film transistor; and
performing a heat treatment on the substrate after the forming of the at least one first dummy hole and the at least one second dummy hole,
wherein numbers or sizes of the at least one first dummy hole and at least one second dummy hole are different from each other.
16. The method of claim 15, wherein the substrate comprises a display area comprising a plurality of pixels, and wherein the first thin film transistor and the second thin film transistor are located in at least one of the plurality of pixels.
17. The method of claim 16, wherein the first thin film transistor comprises a driving thin film transistor and the second thin film transistor comprises a switching thin film transistor, and wherein a number or a size of the at least one first dummy hole is greater than a number or a size of the at least one second dummy hole.
18. The method of claim 15, wherein the substrate comprises a display area comprising a plurality of pixel regions and a non-display area surrounding the display area, and wherein the first thin film transistor is located in the pixel region and the second thin film transistor is located in the non-display area.
19. The method of claim 15, wherein the substrate comprises a display area comprising a plurality of pixel regions and a non-display area surrounding the display area, and wherein the first thin film transistor and the second thin film transistor are located in the non-display area.
20. The method of claim 13, further comprising:
forming a protection layer located on the insulating layer, wherein a portion of the protection layer fills the at least one first dummy hole and the at least one second dummy hole.
21. The method of claim 13, further comprising:
forming a third dummy hole passing through the interlayer insulating layer and overlapping the first semiconductor pattern; and
forming a fourth dummy hole passing through the interlayer insulating layer and overlapping the second semiconductor pattern,
wherein the forming of the third dummy hole and the forming of the fourth dummy hole are performed at substantially the same time.
22. An organic light emitting device comprising:
a substrate;
a first thin film transistor having a first semiconductor pattern disposed on the substrate;
a first insulating layer covering the first thin film transistor;

- a second insulating layer covering the first insulating layer;
 a first contact hole passing through the first insulating layer;
 a source/drain electrode filling the first contact hole to be in contact with the first semiconductor pattern;
 a first dummy hole exposing the first semiconductor pattern,
 wherein the second insulating layer is in contact with the first semiconductor pattern through the first dummy hole.
- 23.** The organic light emitting device of claim **22**, further comprising:
 a third insulating layer interposed between the first insulating layer and the second insulating layer,
 wherein the first dummy hole further passes through the second insulating layer.
- 24.** The organic light emitting device of claim **22**, wherein the first insulating layer includes silicon oxide or silicon nitride, and
 wherein the second insulating layer includes an acryl-based organic material or benzocyclobutene (BCB).
- 25.** The organic light emitting device of claim **23**, wherein the first insulating layer includes silicon oxide or silicon nitride, and
 wherein the second insulating layer includes an acryl-based organic material or benzocyclobutene (BCB),
 and
 wherein the third insulating layer includes silicon oxide or silicon nitride.
- 26.** The organic light emitting device of claim **22**, further comprising:
 a second thin film transistor having a second semiconductor pattern disposed on the substrate, wherein the second thin film transistor is covered with the first and second insulating layers;
- a second contact hole passing through the first insulating layer;
 a second source/drain electrode which is in contact with the second semiconductor pattern through the second contact hole;
 a second dummy hole passing through the first insulating layer to expose the second semiconductor pattern,
 wherein the second insulating layer is in contact with the second semiconductor pattern through the second dummy hole.
- 27.** The organic light emitting device of claim **22**, wherein first dummy hole includes a first number of dummy holes and the second dummy hole includes a second number of dummy holes, and
 wherein the first number is greater than the second number.
- 28.** The organic light emitting device of claim **22**, wherein the first dummy hole has a first diameter and the second dummy hole has a second diameter smaller than the first diameter.
- 29.** The organic light emitting device of claim **22**, further comprising:
 a scan signal line;
 a power line;
 a storage capacitor having a first electrode and a second electrode,
 wherein the scan line is connected to a gate electrode of the second thin film transistor,
 wherein the second electrode is connected to the power line, and
 wherein the first electrode serves as a gate electrode of the first thin film transistor.

* * * * *

专利名称(译)	薄膜晶体管及其制造方法，以及包括该薄膜晶体管的有机发光显示装置		
公开(公告)号	US20170271422A1	公开(公告)日	2017-09-21
申请号	US15/455563	申请日	2017-03-10
[标]申请(专利权)人(译)	三星显示有限公司		
申请(专利权)人(译)	三星DISPLAY CO. , LTD.		
当前申请(专利权)人(译)	三星DISPLAY CO. , LTD.		
[标]发明人	KIM DEOKHOI TAE SEUNGGYU		
发明人	KIM, DEOKHOI TAE, SEUNGGYU		
IPC分类号	H01L27/32 H01L51/52		
CPC分类号	H01L27/3262 H01L27/3276 H01L2227/323 H01L27/3258 H01L51/5253 H01L21/77 H01L27/1222 H01L27/1259 H01L27/32 H01L51/56 H01L27/124 H01L27/1248		
优先权	1020160032914 2016-03-18 KR		
外部链接	Espacenet USPTO		

摘要(译)

如下提供有机发光显示装置。具有第一半导体图案的第一薄膜晶体管设置在基板上。具有第二半导体图案的第二薄膜晶体管设置在基板上。绝缘层覆盖第一薄膜晶体管和第二薄膜晶体管。穿过绝缘层的至少一个第一虚设孔与第一薄膜晶体管的第一半导体图案重叠。穿过绝缘层的至少一个第二虚设孔与第二薄膜晶管的第二半导体图案重叠。所述至少一个第一虚设孔和所述至少一个第二虚设孔的数量或尺寸彼此不同。

